

**ALD Vacuum Technologies**

High Tech is our Business



## **VIM 100 - VIM 4000**

Vacuum Induction Melting and Casting Furnaces



# Vacuum Induction Melting and Casting

Vacuum induction melting is one of the most common processes in secondary metallurgy. It enables an effective degassing of the melt and precise adjustment of alloy composition.

The application of vacuum in the induction melting process is indispensable for the production of high purity metals that react with atmospheric oxygen. The vacuum melting process limits the formation of non-metallic oxide

inclusions that are responsible for premature part failure. Particularly critical applications such as jet engine parts demand the production of alloys with a very low concentration of undesired volatile trace elements.

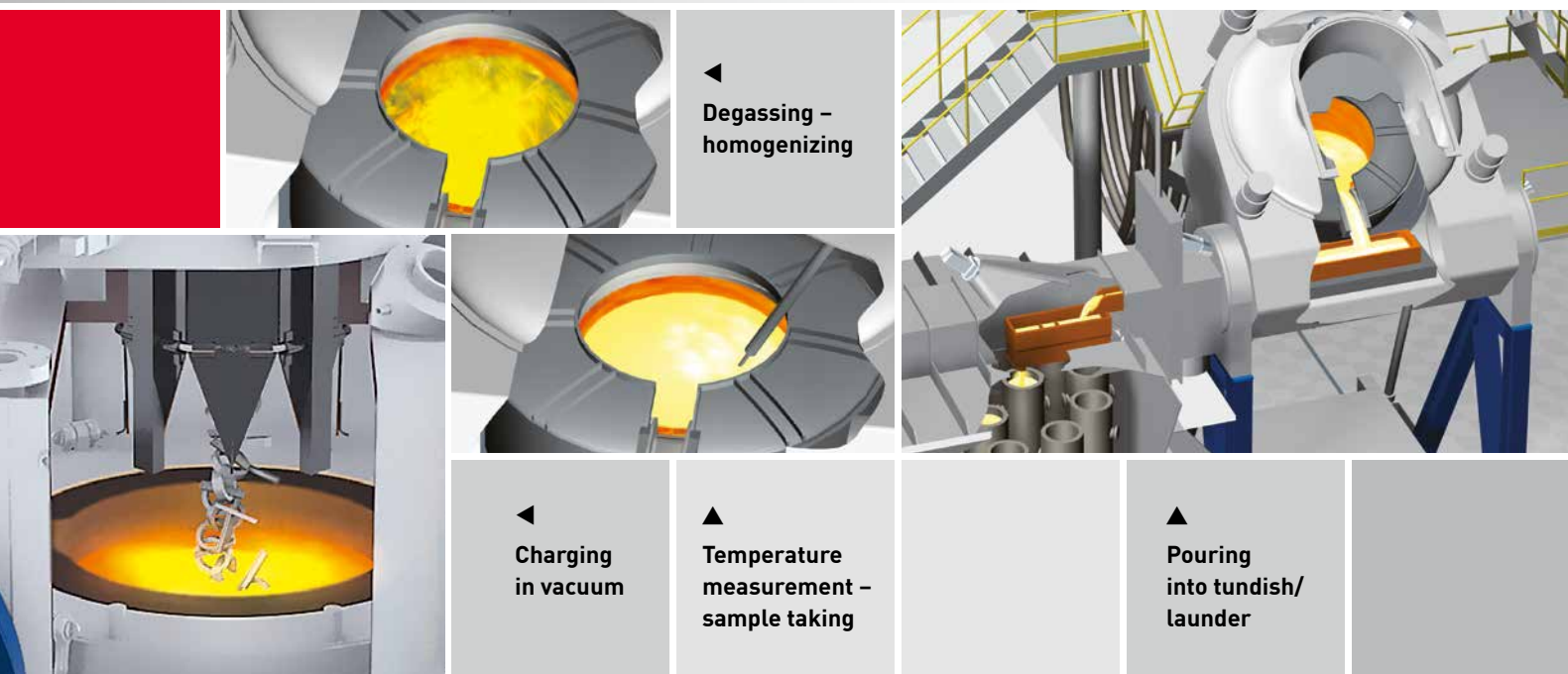

## VIM process characteristics

- Environment friendly
- High flexibility and versatility
- Fast process change
- High efficiency due to optimum refining
- Close compositional tolerances
- Precise temperature control
- Removal of undesired elements

Vacuum induction melting enables an extremely precise adjustment of the alloy composition and melt homogenization since

- melt temperature,
- vacuum,
- gas atmosphere,

- pressure and
- kinetics

can be adjusted independently. Several casting processes can be combined with VIM technology.

## Applications

- Special steels, superalloys and non-ferrous alloys
- Semi-finished products, such as:
  - Electrodes for remelting
  - Ingots for wrought products
  - Bar stocks for investment casting

## Final products are used for

- Aerospace
- Power generation
- Electronics
- Chemical industry
- Medical devices
- Automotive industry
- Tool making

# Indispensable for High Purity Metals

Cleanliness, Homogenization,  
Reproducibility

## Process reproducibility/control

### PC/PLC-control and automation

#### Exact process control

- Melt bath and pouring temperatures
- Vacuum conditions
- Leak-up rate control
- Cooling water conditions
- Data acquisition
- Maintenance diagnostic system
- Energy management
- Melt-trend analysis
- Pouring weight

All relevant process steps are monitored via video cameras, operation of the process primarily from the control room.

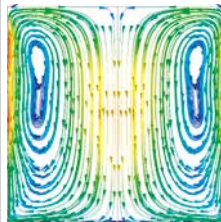

◀ Melt bath movement during melting mode

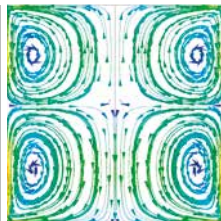

◀ Melt bath movement during 3-phase-stirring mode

## Improvement in oxide cleanliness

- Removal of non-metallic inclusions
  - Soft rinsing of inert gas through the melt
  - Agglomeration at the crucible
  - Flotation and agglomeration in a transfer hot launder with slag barriers (dam and weirs)
  - Additional ceramic filter – pore size 20-50 ppi

## Melt homogenization, melt stirring

- 3-Phase, 50 Hz electromagnetic stirring
  - Homogeneity chemical composition melt temperature
  - Increased yield of adding volatile elements
  - Shorter degassing time
  - Most effective degassing without energy input and overheating

# VIM Concepts

Tailored to Solve  
Customers' Needs



**Version F** – Melt chamber with front door arrangement

- 1** Vacuum system
- 2** Launder chamber
- 3** System control deck
- 4** Mold chamber
- 5** VIM melting chamber
- 6** Charging device
- 7** Power supply



▲ **Version R** – Crucible tilting with rope design

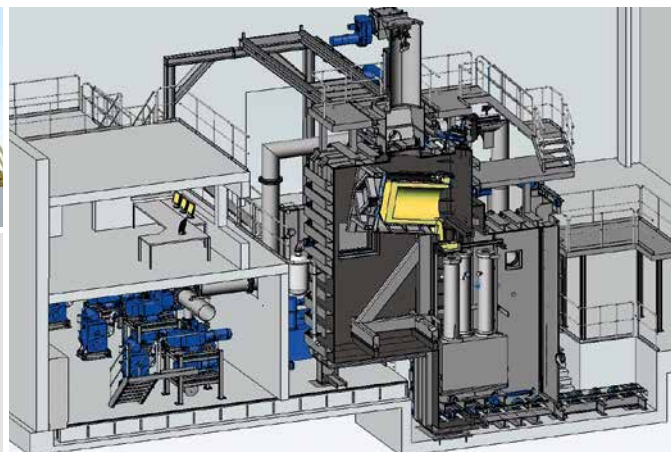

▲ **Version S** – Melt chamber with side door arrangement

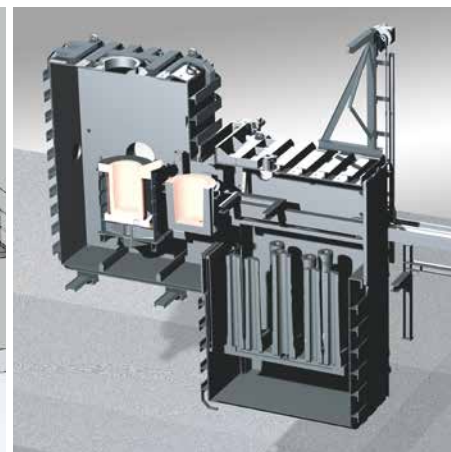

▲ **Version L** – Furnace concept with ladle technology

ALD specializes in developing and implementing system designs tailored to customer specific needs. From analyzing your needs to design, planning, engineering, construction, startup, we can do a customized job.

ALD does not only produce standard products but solves process-engineering and metallurgical requirements.

# Version VIDP

The Most Successful Concept  
in VIM Furnace Technology

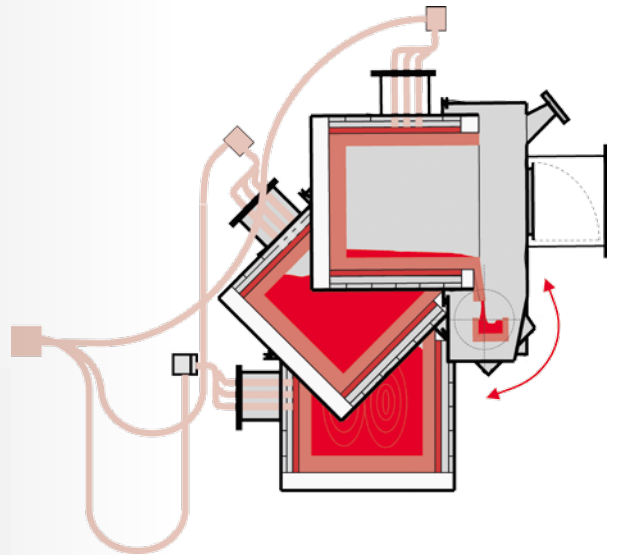

▲ **Tiltable melting chamber with transfer launder and separate casting chamber**

▲ **Casting controlled tilting of the entire furnace housing**

## Small furnace volume

(1:10 compared to chamber type furnaces) and small internal furnace surfaces

- Lowest desorption surfaces and low gas emission
- Large melt surface and better relationship for boundary dependant reactions and thus high degassing rates
- Smaller vacuum pumping system
- Optimum control of the furnace atmosphere
- Low inert gas consumption

## Easily maintainable

- Power cables and hydraulic lines are outside the melting chamber – leaks do not affect the vacuum
- Simple maintenance of the vacuum pumps through effective filter system
- Smaller vacuum pumping system
- Tried and tested components, preventative fault diagnostics

## High flexibility

- Through a range of interchangeable lower furnace bodies
- Variable pouring technologies (ingot casting, horizontal continuous casting, powder production)

- Unit can be modularly expanded
- Connection to multiple casting chambers

## Fast furnace change

- < 1 hour with hot crucible
- High operating availability
- Increased productivity by up to 25 %
- Rapid alloy change
- Separate crucible break out and relining stations
- Quick changing of the furnace body and quick crucible cleaning for an alloy change as well as effective loading/packing of the crucible



## Technical Data

		VIM 100	VIM 200	VIM 400	VIM 800	VIM 1000	VIM 1000	VIM 2500	VIM 4000
<b>Crucible Size</b> Capacity (based on Ni)	[metric tons]	1	2	4	6	8	12	24	30
<b>Typical Cycle Times</b> Ni-Co base alloys	[h]	3-4	3-4	4-5	6-8	6-8	6-8	6-8	12
<b>Recommended Power Supply for Melting</b> MF power at 600 V output Frequency	[kW] [KHz]	500 200-250	750 200-250	1000 200-250	2000 200-250	2400 200-250	3000 200-250	4000 200-250	5000 200-250
<b>Electr. Connected Loads incl. Vacuum Pumping Unit</b> Line-voltage data	[kVA]	200	200	250	250	250	300	300	350
According to customer mains									
<b>Cooling Water</b> Total consumption ( $\Delta t=10\text{ }^{\circ}\text{C}$ )	[m <sup>3</sup> x h <sup>-1</sup> ]		approx. 80		approx. 120		approx. 200		approx. 250
<b>Floor Area</b> Length (L) x Width (W) Height	L x W [m] [m]		20 x 18 8		25 x 20 10		30 x 20 12		35 x 20 12
<b>Recommended Crane Capacity</b>	[metric tons]	10	15	20	30	30	50	60	70

### ALD Vacuum Technologies GmbH

Otto-von-Guericke Platz 1  
63457 Hanau, Germany  
Phone +49 6181 307-0  
Fax +49 6181 307-3290  
E-Mail info@ald-vt.de  
Internet www.ald-vt.de

### USA/Canada

**ALD Vacuum Technologies Inc.**  
18 Thomson Road  
East Windsor, CT 06088, USA  
Phone +1 (860) 386 7227  
E-Mail info@ald-usa.com

### Far East (Japan/Korea/Taiwan)

**ALD Thermo Technologies**  
Far East Co., Ltd.  
Shinjuku Nomura Bldg. 6F  
1-26-2 Nishi Shinjuku  
Shinjuku-ku  
Tokyo 163-0558, Japan  
Phone +81 (3) 3340 3726  
E-Mail peter.lang@ald-vt.de

### China

**ALD-C&K Vacuum Technologies (Suzhou) Co. Ltd.**  
333 Yegang Road  
Wujiang Economic and Technological Development Zone  
Suzhou, 215200, P. R. China  
Phone +86 512 6385 8833  
E-Mail info@ald-cnk.com

### Russia

**ALD Vacuum Technologies GmbH Daev per., 20**  
Moskow, Russia  
Phone +7 (495) 787 6733  
E-Mail ald@metallurg.com.ru